

**ODSIL 96B**

**Optical laser distance sensors**

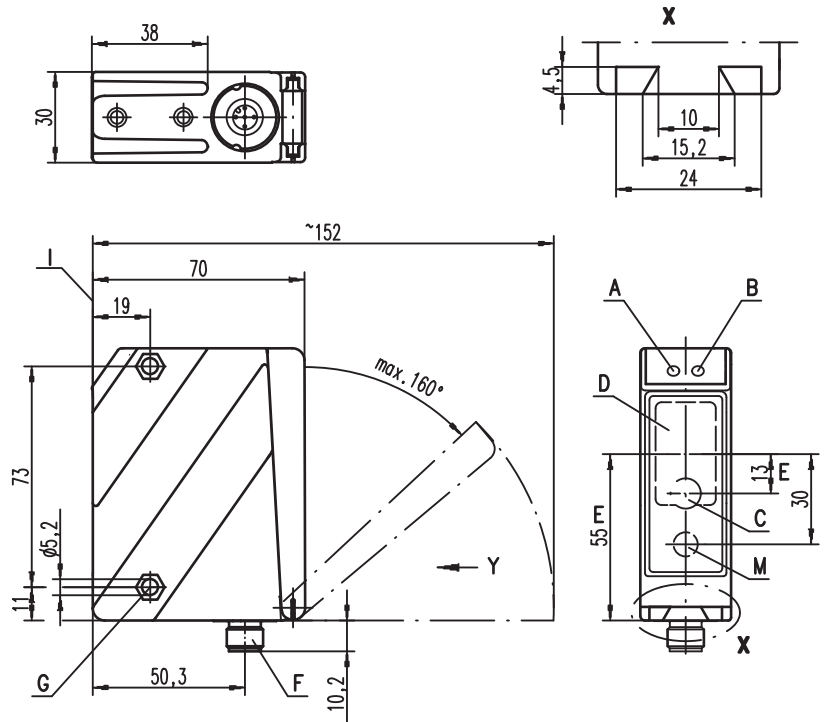

**Dimensioned drawing**



- A Green indicator diode
- B Indicator diode yellow
- C Transmitter (infrared light) for distance measurement
- D Receiver
- E Optical axis
- F Device plug M12x1
- G Countersinking for SK nut M5, 4.2mm deep
- H OLED display
- I Reference edge for the measurement (cover glass)
- K Key pad
- L Green and yellow indicator diodes
- M Transmitter (red light) as alignment aid
- N Button for switching red alignment laser on/off

**Electrical connection**

ODSIL 96B M/C6...

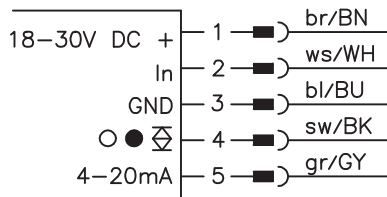

ODSIL 96B M/V6...

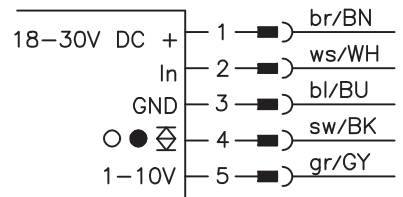

en 03-2013/01 50114025

We reserve the right to make changes • DS\_ODSIL96BMTOF\_en\_50114025.fm

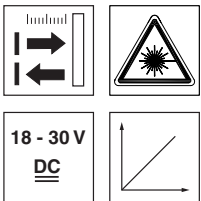

**0.3 ... 10m**

- Measurement range up to 10000mm at 90% diffuse reflection
- Reflection-independent distance information up to 6000mm
- Infrared laser diode with laser class 1
- Switchable alignment aid with red light laser diode with laser class 1
- Highly insensitive to extraneous light
- Analog current or voltage output
- PC/OLED display and membrane keyboard for configuration
- Measurement value is indicated in mm on OLED display
- Measurement range and mode adjustable
- Input (pin 2) for deactivation of laser, triggering, offset correction or teach-in



**Accessories:**

(available separately)

- Mounting systems
- Cable with M12 connector (K-D ...)
- Configuration software

## Specifications

### Optical data

Measurement range	300 ... 10000mm (90% diffuse reflection), 300 ... 6000mm (6 ... 90% diffuse reflection)
Resolution	3mm
Light source	laser
Wavelength	measurement laser: 785nm (infrared light), alignment laser: 658nm (visible red light)
Light spot	approx. 7x7mm <sup>2</sup> at 10m
Max. output power	measurement laser: 268mW, alignment laser: 190mW
Pulse duration	measurement laser: 6.5ns, alignment laser: 6.5ns

### Error limits (relative to measurement range end value 6000mm)

Absolute measurement accuracy <sup>1)</sup>	± 0.5%
Repeatability <sup>2)</sup>	± 5mm
B/W detection thresh. (6 ... 90% rem.)	± 10mm
Temperature drift	± 1.5mm/K

### Timing

Measurement time	"Fast" operating mode: 2.8ms "Standard" operating mode: 20ms "Precision" operating mode: 100ms (factory setting)
Delay before start-up	≤ 300ms

### Electrical data

Operating voltage U <sub>B</sub>	...C6/V6 18 ... 30VDC (incl. residual ripple)
Residual ripple	≤ 15% of U <sub>B</sub>
Open-circuit current	≤ 150mA
Switching output	push-pull switching output <sup>3)</sup> , PNP light switching, NPN dark switching
Signal voltage high/low	≥ (U <sub>B</sub> -2 V)/≤ 2V
Analogue output	...V6 voltage 1 ... 10V / 0 ... 10V / 1 ... 5V / 0 ... 5V, R <sub>L</sub> ≥ 2kΩ ...C6 current 4 ... 20mA, R <sub>L</sub> ≤ 500Ω

### Indicators

Green LED	continuous light off	<b>Teach-in on GND</b> ready no voltage
Yellow LED	continuous light off	object within range / switching output object out of range / switching output

### Mechanical data

Housing	diecast zinc
Optics cover	glass
Weight	380g
Connection type	M12 connector

### Environmental data

Ambient temp. (operation/storage)	-20°C ... +50°C / -30°C ... +70°C
Protective circuit <sup>4)</sup>	1, 2, 3
VDE safety class <sup>5)</sup>	II, all-insulated
Protection class	IP 67, IP 69K <sup>6)</sup>
Laser class	1 (acc. to EN 60825-1)
Standards applied	IEC 60947-5-2

- 1) For 300 ... 6000mm measurement range, luminosity coefficient 6% ... 90%, "Precision" operating mode, floating average calculation taking 30 measurement values into account, at 20°C after 20 min. warmup time, medium range of U<sub>B</sub>, measurement object ≥ 50x50mm<sup>2</sup>
- 2) Same object, identical environmental conditions, "Precision" operating mode, floating average calculation taking 30 measurement values into account, after 20 min. warmup time, measurement object ≥ 50x50mm<sup>2</sup>
- 3) The push-pull switching outputs must not be connected in parallel
- 4) 1=transient protection, 2=polarity reversal protection, 3=short circuit protection for all outputs
- 5) Rating voltage 250VAC, with cover closed
- 6) IP 69K test in accordance with DIN 40050 part 9 simulated, high pressure cleaning conditions without the use of additives. Acids and bases are not part of the test

## Order guide

### Analogue current output

Current output, teach input, 1 push/pull output

Designation	Part no.
ODSIL 96B M/C6-S12	50109302

### Analogue voltage output

Voltage output, teach input, 1 push/pull output

ODSIL 96B M/V6-S12	50109303
--------------------	----------

## Tables

## Diagrams

## Remarks

- **Approved purpose:**  
This product may only be used by qualified personnel and must only be used for the approved purpose. This sensor is not a safety sensor and is not to be used for the protection of persons.
- The red light laser diode is used exclusively as an alignment aid. The beam radiates at a distance of 17mm parallel to the infrared measurement beam (see dimensioned drawing).

**Analog output: characteristic curve for factory setting**

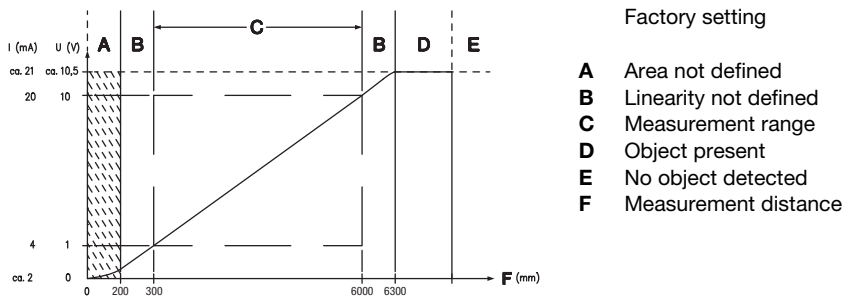

**Measurement mode and measurement filter**

The user can individually adapt the measurement system of the ODSIL 96B to various applications. By configuring the measurement mode and measurement filter, either a higher measurement accuracy or, alternatively, faster measurements can be achieved. Configuration can be performed either directly on the sensor or with the ODS 96B configuration software.

**Optimization of measurement mode**

In the Application menu, you can set 3 different measurement filters.

Menu setting	Effect
Application -> Measure Mode -> Precision	high accuracy, measurement time of individual measurement: 100ms
Application -> Measure Mode -> Standard	exact and fast, measurement time of individual measurement: 20ms
Application -> Measure Mode -> Speed	fast measurement, measurement time of individual measurement: 2.8ms

**Optimization of measurement filter**

To achieve more precise measurement values, a measurement filter can be adjusted in addition to the measurement mode. In most cases, the use of a floating average results in a reduction in the variance of the measurement values.

To use this, select the menu setting **Application -> Measure Filter -> Averaging**.

The number of measurement values to be taken into account can be set to a value between **1 ... 99** via menu setting **Application -> Measure Filter -> Averaging -> Measurment. Count**.



**Notice!**

The measurement value display on the OLED display can be used to assess the efficiency of the selected measurement mode and measurement filter in the application. The update rate of the OLED display is always 2Hz. The ODS 96B configuration software provides identical functionality.

**Factory setting of measurement mode:**

On delivery, the sensor is preset so that measurement values with the maximum possible accuracy are achieved:

- Measurement mode **Precision**.

**Reset to factory settings**

Press the **↵** button while switching on the device to reset the configuration of the ODSIL 96B to the state upon delivery from the factory.

Press the **↵** button again to reset all parameters to the factory settings. All settings made previously are permanently lost.

Press **▼** and the ODSIL 96B returns to measurement operation without resetting the parameters.



You can also use the menu or the configuration software to reset to factory settings. For this purpose, select menu item **Settings -> FactorySettings -> Execute**.

The ODS 96B configuration software can also be used to reset the ODSIL 96B to factory settings.

## Teach-in of switching outputs, analog characteristic output curve and Preset



**Notice!**



If you have changed the factory setting for teaching under Input Mode, activate on the OLED display the menu item **Input -> Input Mode -> Teach**.

To teach, proceed as follows:

1. Position measurement object at the desired measurement distance.
2. The respective teach function is activated on the teach input for the duration of a level change **T** (see graphical representation).  
The level conditions describe the levels with menu setting **Input -> Input Mode -> Input polarity -> Active High +24V** (factory setting).

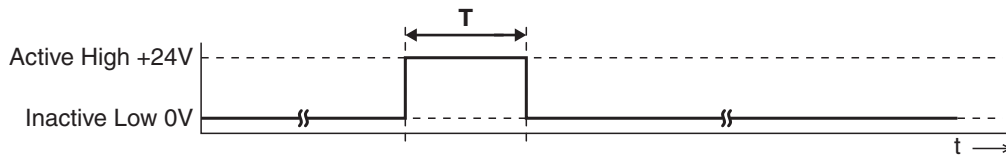

Teach function	Duration T
Switching output Q1	20 ... 80ms
Distance value for start of measurement range = 1V or 4mA at analog output	220 ... 280ms
Distance value for end of measurement range = 10V or 20mA at analog output	320 ... 380ms



**Notice!**



If the inactive level is continuously applied on the teach input, the teach input is locked.

For menu setting **Input -> Input Mode -> Input polarity -> Active Low +0V**, inverted input signals are used during teaching.

### Preset Teach-In

On the OLED display, activate for this purpose menu item **Input -> Input Mode -> Preset**.

The preset teach occurs in a manner analogous to that for the teach-in for switching output Q1.